



Dragflow Hydraulic Pump

HY85-160

Parts
Service line Ports: SAE J518 1 1/4in
Case drain Port: DIN3852 M22x1,5

Operating Conditions
Max liquid temperature 40°C
Min Submersion depth 440mm

Model HY85-160

Brake Power [kW HP]	120 kW	165 HP
Efficiency [%]	51	
RPM Max	1450	
Motor Displacement [cc]	160	
Oil flow rate max [l/min]	240	
Nominal pressure [bar]	300	
Max pressure [bar]	350	
Solid Handling	60 mm	2.4"
Discharge [DN PN]	200	PN10

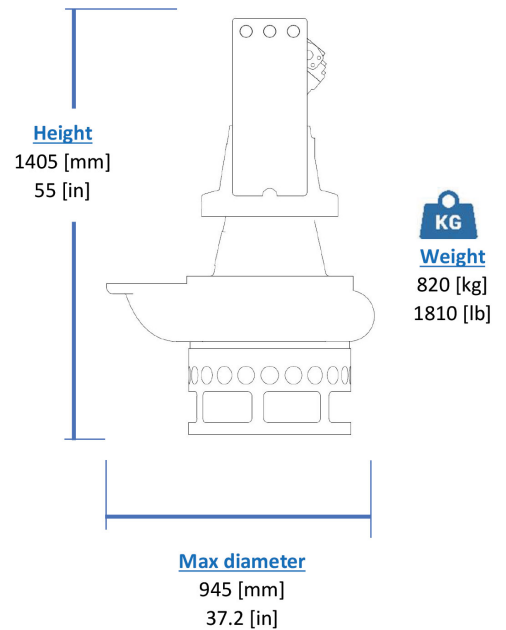

Materials

Part	Standard
Casing	Cast Iron EN-GJS500
Body	Cast Iron EN-GJL250
Wear Parts	High chrome EN-GJN-HV600 (CH6)
Minimum hardness [HB]	550
Main shaft	High tensile 39NiCrMo3
PH Range	5-10

Seals and lubricants

Version	HY85-160	MG	MS
Motor Side	LIPS	MECHANICAL	MECHANICAL
Impeller Side	LIPS	LIPS	MECHANICAL
Oil type	EP320	ISO32	ISO32

